



SPECIFICATION SHEET

SPECIFICATION SHEET NO.	Q0721- TO252MDD7N65DS
DATE	July. 21, 2023
REVISION	A0
DESCRIPTION	SMD Plastic-Encapsulate MOSFETS, TO -252 series, 3 Pins MDD7N65D Type, 650V N-Channel Enhancement Mode MOSFET Drain-Source Voltage: 650V, Continuous Drain Current 7.0A Junction Temperature: +150°C, Package in Tape/Reel, 2500pcs/13" Reel RoHS/RoHS III compliant
CUSTOMER	
CUSTOMER PART NUMBER	
CROSS REF. PART NUMBER	
ORIGINAL PART NUMBER	MDD7N65D
PART CODE	TO252MDD7N65DS

VENDOR APPROVE			
Issued/Checked/Approved			
DATE: July. 21, 2023			

CUSTOMER APPROVE	
DATE:	
7/21/2023	

SMD PLASTIC-ENCAPSULATE MOSFETS TO-252 SERIES

MAIN FEATURE

- Ultra Low Gate Charge
- Low Reverse Transfer Capacitance
- Fast Switching Capability
- Avalanche Energy Tested
- Improved dv/dt Capability and High Ruggedness



APPLICATION

- High Efficiency Switch Mode Power Supplies
- Electronic Lamp Ballasts Based On Half Bridge
- LED Power Supplies

RFQ
Request For Quotation

PART CODE GUIDE

TO252	MDD	7N65	DS
1	2	3	4

- 1) **TO252**: SMD Plastic-Encapsulate MOSFETS, TO-252 series, 3 pins
- 2) **MDD**: Original Supplier QC Code
- 3) **7N65**: Main Specification code for I_D: 7A , N: N-Channel and V_{DS} : 650V
- 4) **DS**: Internal Control Code, (A~Z or 1~9 or Blank) or custom parametric data

SMD PLASTIC-ENCAPSULATE MOSFETS TO-252 SERIES

DIMENSION (Unit: Inch/mm)

Image for reference



Marking: 7N65D

TO-252

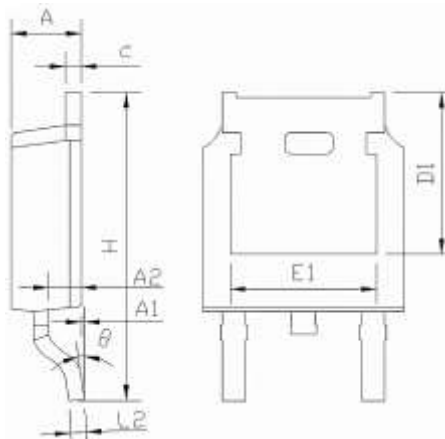
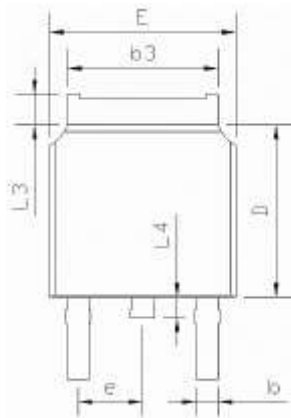

Symbol	Value (mm)		
	Min.	Typ.	Max.
A	2.20	2.30	2.38
A1	0.00	-	0.20
A2	0.97	1.07	1.17
b	0.68	0.78	0.90
b3	5.20	5.33	5.46
c	0.43	0.53	0.61
D	5.98	6.10	6.22
D1	5.30 REF		
E	6.40	6.60	6.73
E1	4.63	-	-
e	2.286 BSC		
H	9.40	10.1	10.5
L2	0.51 BSC		
L3	0.88	-	1.28
L4	0.50	-	1.00
θ	0°	-	8°

EQUIVALENT CIRCUIT DIAGRAM

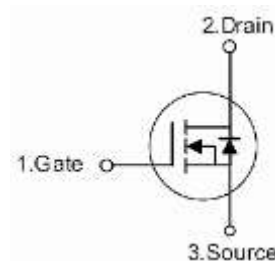

SMD PLASTIC-ENCAPSULATE MOSFETS TO-252 SERIES
650V N-CHANNEL ENHANCEMENT MODE MOSFET

V (BR)DSS	I D (TC+ 25°C)	R DS (on),max	Q g,typ
650V	7A	1.4 Ω @ VGS=10V	20.7 nC

ABSOLUTE MAX. RATINGS AT (Ta=25 °C unless otherwise specified)

Parameter	SYMBOLS	VALUE	UNIT
Drain-Source Voltage	V DS	650	V
Gate-Source Voltage	V GS	±30	V
Continuous Drain Current	I D	7.0	A
Pulsed Drain Current(Note 1)	I D	28	A
Avalanche Energy Single Pulsed (Note 2)	E AS	352	mJ
Continuous diode forward current	I S	7	A
Diode pulse current	I S,pulse	28	A
Peak Diode Recovery dv/dt (Note 3)	dv/dt	5.0	V/ns
Power Dissipation (TO-252)	P D	100	W
Junction Temperature	T J	+150	°C
Storage Temperature Range	T STG	-55 ~ +150	°C

THERMAL CHARACTERISTICS

Parameter	SYMBOLS	VALUE (TO-252)	UNIT
Thermal resistance, Junction-to-case	R θJC	1.25	°C/W
Thermal resistance, Junction-to-ambient	R θJA	110	°C/W

Notes:

1. Pulse width limited by maximum junction temperature. 2. L=10mH, I AS = 8.4A, Starting T j= 25°C.
3. I SD = 7A, di/dt≤100A/us, VDD≤BVDS, Starting Tj= 25°C.

SMD PLASTIC-ENCAPSULATE MOSFETS TO-252 SERIES
MOSFET ELECTRICAL CHARACTERISTICS AT Ta=25 °C (unless otherwise specified)

Parameter		SYMBOLS	VALUE			UNIT	Condition
			Min.	Typ.	Max.		
Drain-Source Breakdown Voltage		V (BR) DSS	650	-	-	V	VGS=0V I D=250μA
Gate-Source Leakage Current	Forward	I GSS	-	-	100	nA	VGS=30V, VDS=0V
	Reverse		-	-	-100	nA	VGS=-30V, VDS=0V
Drain-Source Leakage Current		I DSS	-	-	1	μA	VDS=650V, VGS=0V
Gate Threshold Voltage		V GS(TH)	2.0	-	4.0	V	VDS=VGS, ID=250μA
Drain-Source On-State Resistance		R DS (ON)	-	1.2	1.4	Ω	VGS=10V, IDS=3.5A

DYNAMIC ELECTRICAL CHARACTERISTICS

Parameter		SYMBOLS	VALUE			UNIT	Condition
			Min.	Typ.	Max.		
Input Capacitance		C iss	-	1090	-	pF	V DS=25V V GS=0V f =1MHz
Output Capacitance		C oss	-	111	-		
Reverse Transfer Capacitance		C rss	-	6.1	-		
Total Gate Charge		Q g	-	20.7	-	nC	VDS=520V V GS =10V ID=7A (Note1, 2)
Gate Source Charge		Q gs	-	5.7	-		
Gate Drain Charge		Q gd	-	7.2	-		

SMD PLASTIC-ENCAPSULATE MOSFETS TO-252 SERIES
SWITCHING CHARACTERISTICS

Parameter	SYMBOLS	VALUE			UNIT	Condition
		Min.	Typ.	Max.		
Turn on Delay Time	t _{d(on)}	-		12.2	ns	V _{DD} =325V I _D =7.0A R _G = 10Ω (Note 1, 2)
Turn on Rise Time	t _r	-		33.4		
Turn Off Delay Time	t _{d(off)}	-		53.6		
Turn Off Fall Time	t _f	-		15		

SOURCE DRAIN DIODE CHARACTERISTICS

Parameter	SYMBOLS	VALUE			UNIT	Condition
		Min.	Typ.	Max.		
Source drain current (Body Diode)	I _{SD}	-	-	7	A	
Pulsed Current	I _{SM}	-	-	28	A	
Drain-Source Diode Forward Voltage	V _{SD}	-	0.85	1.5	V	I _S =7A, V _{GS} =0V
Body Diode Reverse Recovery Time	T _{rr}	-	373.2	-	ns	V _R =325 V I _F =7A, -diF/dt =100A/μs
Body Diode Reverse Recovery Charge	Q _{rr}	-	2.1	-	uC	

Notes:

1. Pulse test ; Pulse width ≤ 300us, duty cycle ≤ 2%. 2. Essentially independent of operating temperature.

SMD PLASTIC-ENCAPSULATE MOSFETS TO-252 SERIES
RELIABILITY

Number	Experiment Items	Experiment Method And Conditions	Reference Documents
1	Solder Resistance Test	Test 260°C± 5°C for 10 ± 2 sec. Immerse body into solder 1/16" ± 1/32"	MIL-STD-750D METHOD-2031.2
2	Solderability Test	230°C ±5°C for 5 sec.	MIL-STD-750D METHOD-2026.1 0
3	Pull Test	1 kg in axial lead direction for 10 sec.	MIL-STD-750D METHOD-2036.4
4	Bend Test	0.5Kg Weight Applied To Each Lead, Bending Arcs 90 °C ± 5 °C For 3 Times	MIL-STD-750D METHOD-2036.4
5	High Temperature Reverse Bias Test	TA=100°C for 1000 Hours at VR=80% Rated VR	MIL-STD-750D METHOD-1038.4
6	Forward Operation Life Test	TA=25°C Rated Average Rectified Current	MIL-STD-750D METHOD-1027.3
7	Intermittent Operation Life Test	On state: 5 min with rated IRMS Power Off state: 5 min with Cool Forced Air. On and off for 1000 cycles.	MIL-STD-750D METHOD-1036.3
8	Pressure Cooker Test	15 PSIG, TA=121°C, 4 hours	MIL-S-19500 APPENOIXC
9	Temperature Cycling Test	-55°C~+125°C; 30 Minutes For Dwelled Time 5 minutes for transferred time. Total: 10 cycles.	MIL-STD-750D METHOD-1051.7
10	Thermal Shock Test	0°C for 5 minutes., 100°C for 5minutes, Total: 10 cycles	MIL-STD-750D METHOD-1056.7
11	Forward Surge Test	8.3ms Single Sale Sine-wave One Surge.	MIL-STD-750D METHOD-4066.4
12	Humidity Test	TA=65°C, RH=98% for 1000 hours.	MIL-STD-750D METHOD-1021.3
13	High Temperature Storage life Test	150°C for 1000 Hours	MIL-STD-750D METHOD-1031.5

SMD PLASTIC-ENCAPSULATE MOSFETS TO-252 SERIES

SUGGESTED REFLOW PROFILE (For Reference Only)

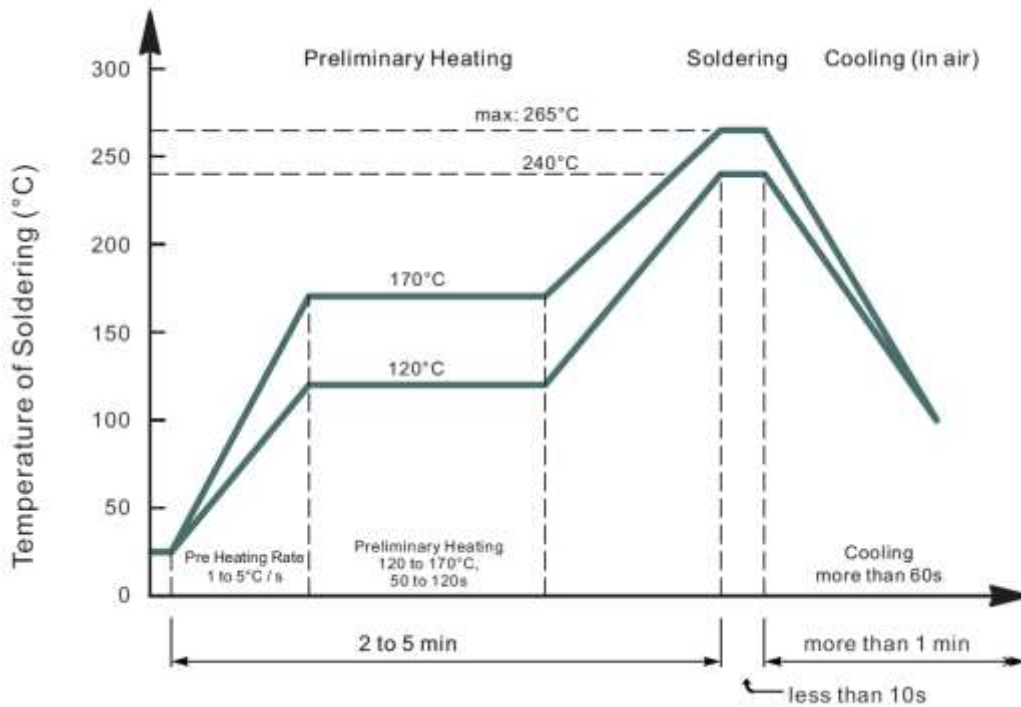

- Recommended peak temperature is over 245°C, If peak temperature is below 245 °C, you may adjust the following parameters; time length of peak temperature (longer), time length of soldering (longer), thickness of solder paste (thicker)
- Welding shall not exceed 2 times
- Remark: lead free solder paste (96.5 sn/3.0 Ag/0.5Cu)

SMD PLASTIC-ENCAPSULATE MOSFETS TO-252 SERIES

ELECTRICAL CHARACTERISTICS DIAGRAMS (For Reference Only)

Figure 1. Typical Output Characteristics

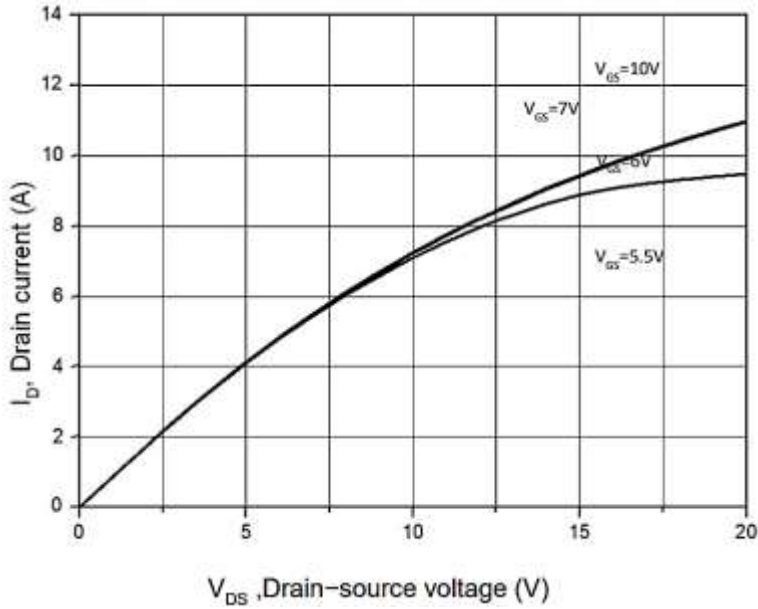
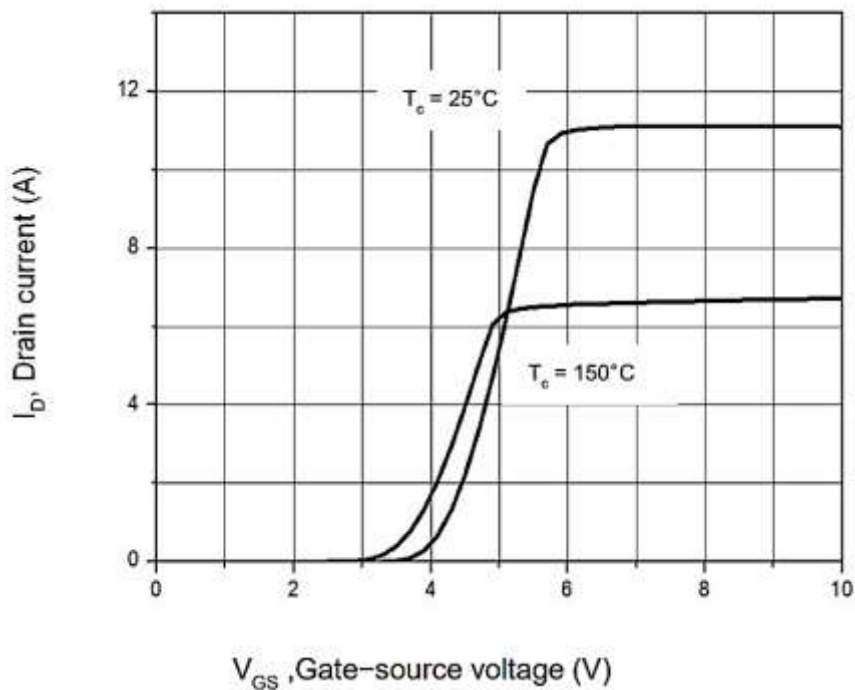

Figure 2. Transfer Characteristics



SMD PLASTIC-ENCAPSULATE MOSFETS TO-252 SERIES

ELECTRICAL CHARACTERISTICS DIAGRAMS (For Reference Only)

Figure 3. On-Resistance Variation vs. Drain Current

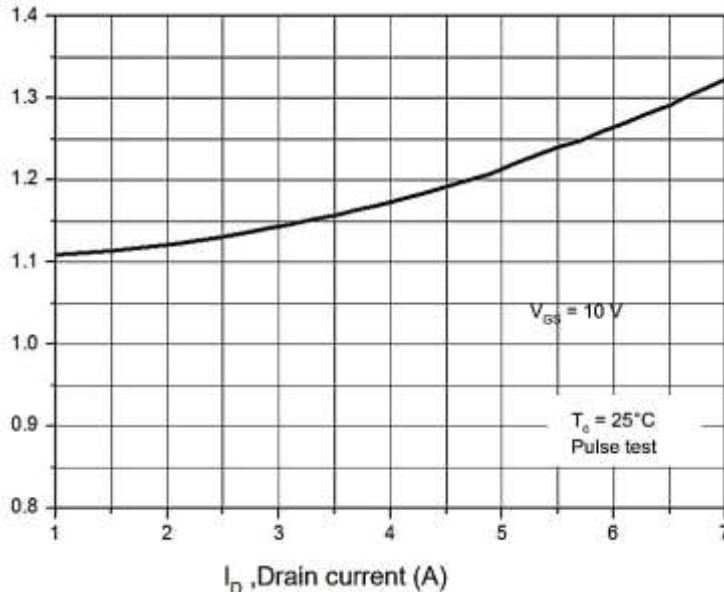
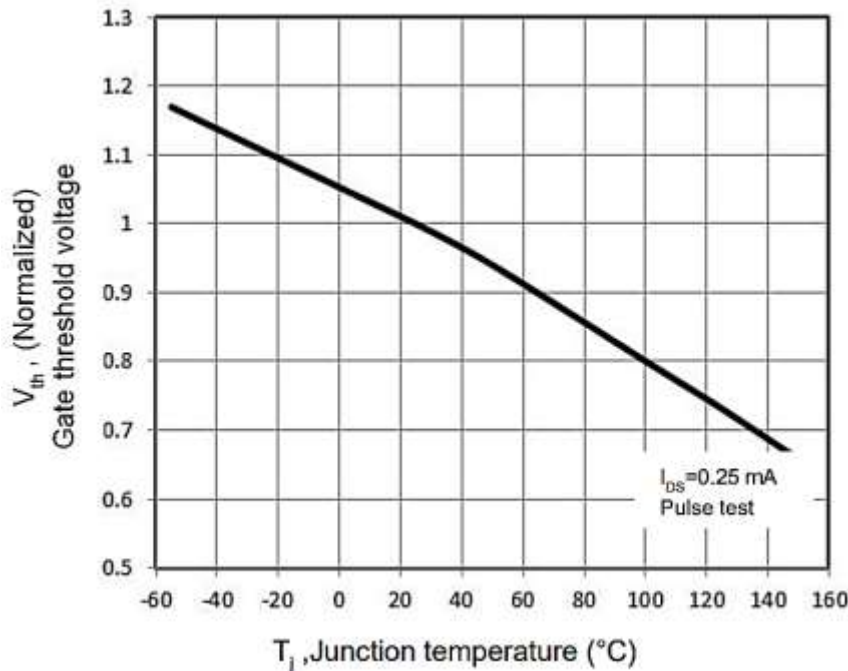

Figure 4. Threshold Voltage vs. Temperature



SMD PLASTIC-ENCAPSULATE MOSFETS TO-252 SERIES

ELECTRICAL CHARACTERISTICS DIAGRAMS (For Reference Only)

Figure 5. Breakdown Voltage vs. Temperature

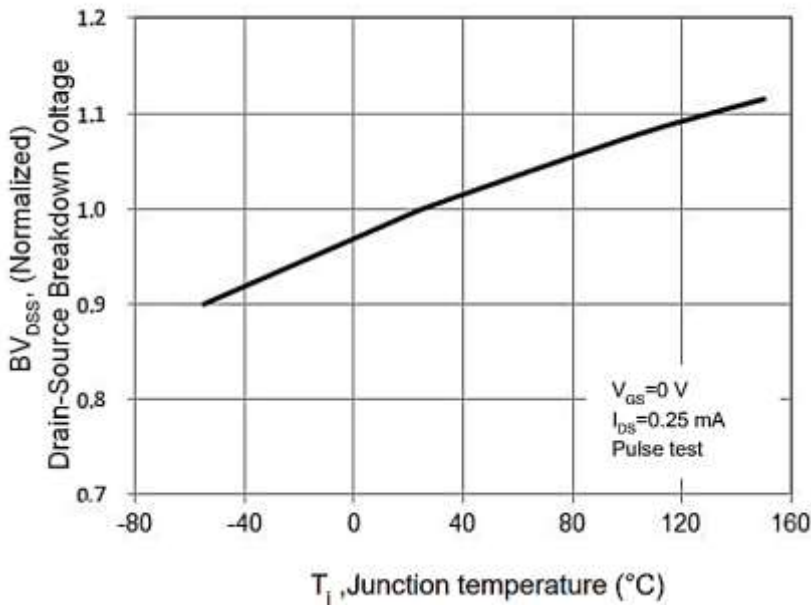
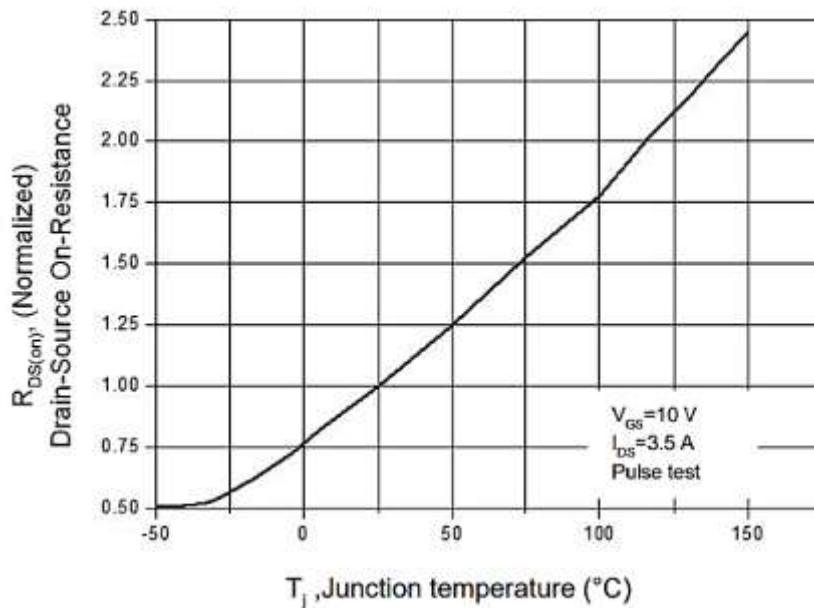

Figure 6. On-Resistance vs. Temperature



SMD PLASTIC-ENCAPSULATE MOSFETS TO-252 SERIES

ELECTRICAL CHARACTERISTICS DIAGRAMS (For Reference Only)

Figure 7. Capacitance Characteristics

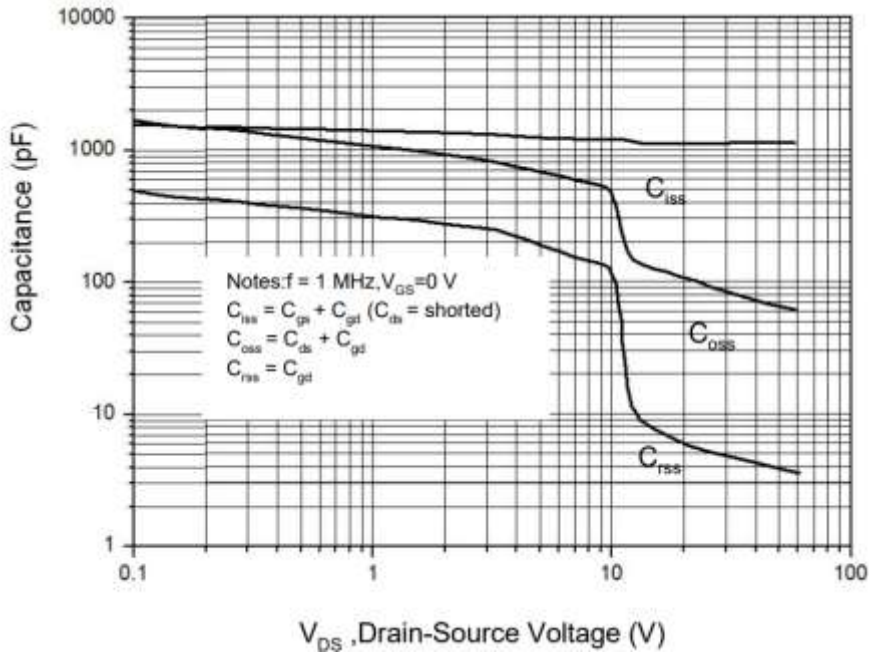
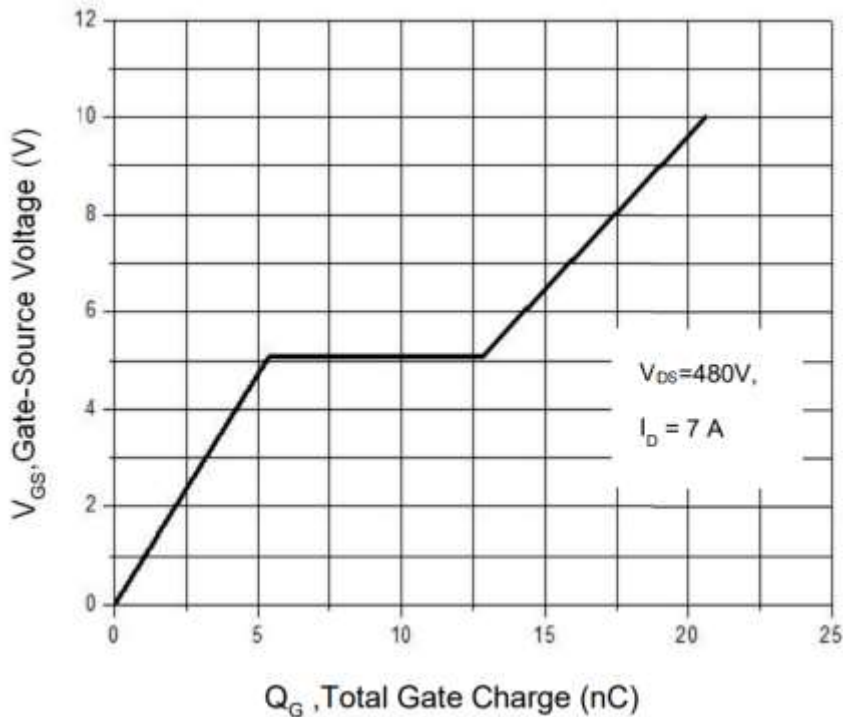

Figure 8. Gate Charge Characterist



SMD PLASTIC-ENCAPSULATE MOSFETS TO-252 SERIES

ELECTRICAL CHARACTERISTICS DIAGRAMS (For Reference Only)

Figure 9. Maximum Safe Operating

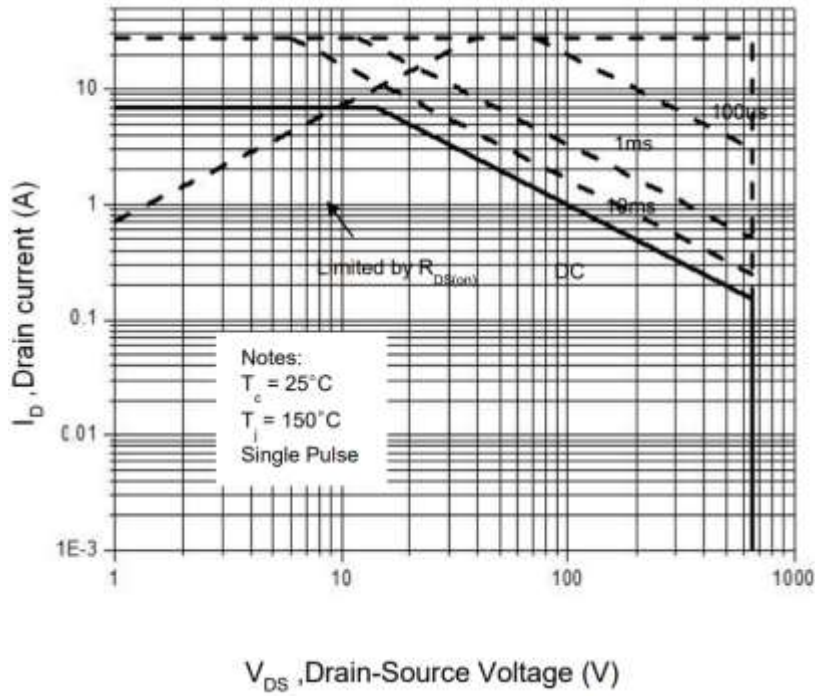
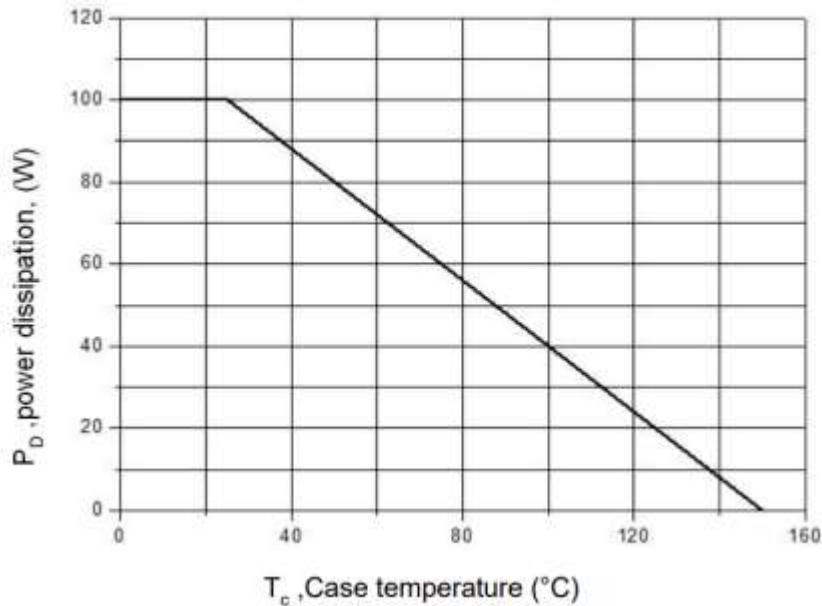

Figure 10. Power Dissipation vs. Temperature



SMD PLASTIC-ENCAPSULATE MOSFETS TO-252 SERIES

ELECTRICAL CHARACTERISTICS DIAGRAMS (For Reference Only)

Figure 11. Continuous Drain Current vs. Temperature

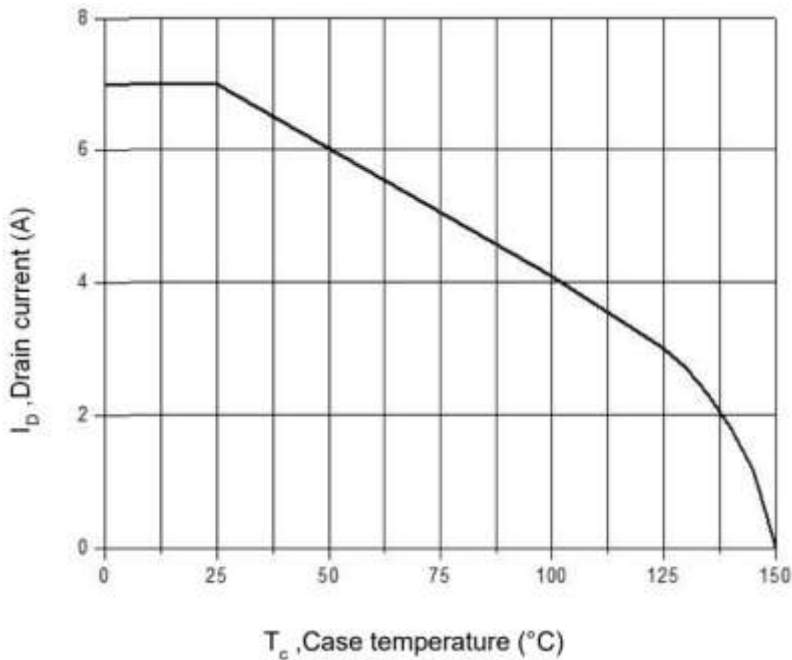
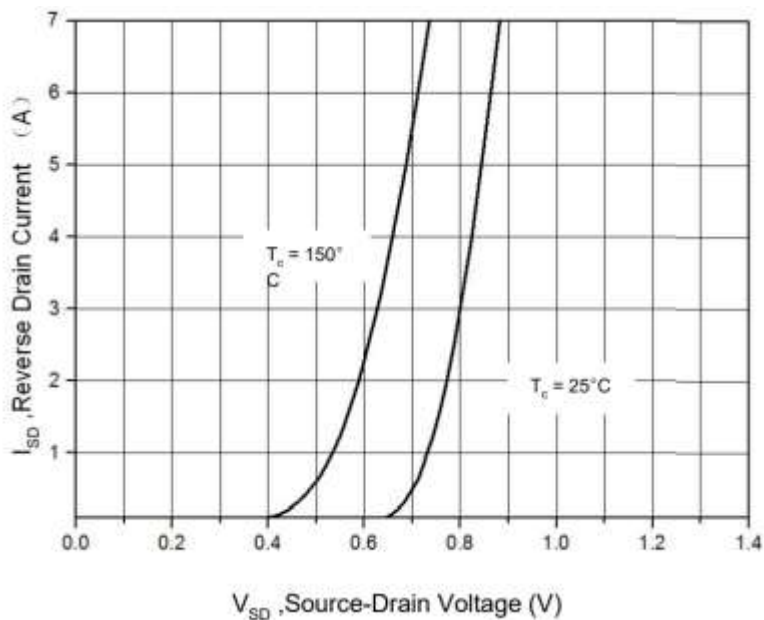

Figure 12. Body Diode Transfer Characteristics



SMD PLASTIC-ENCAPSULATE MOSFETS TO-252 SERIES

ELECTRICAL CHARACTERISTICS DIAGRAMS (For Reference Only)

Figure 13. Transient Thermal Impedance, Junction to Case,

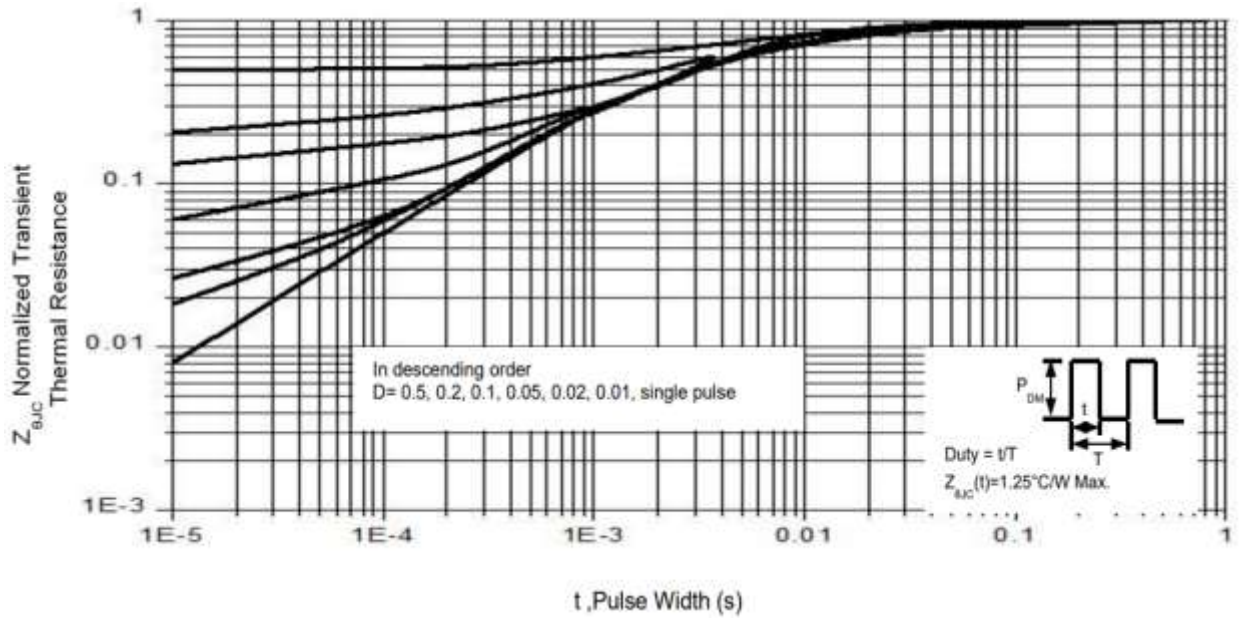

SMD PLASTIC-ENCAPSULATE MOSFETS TO-252 SERIES

TEST CIRCUIT AND WAVEFORMS CURVE (For Reference Only)

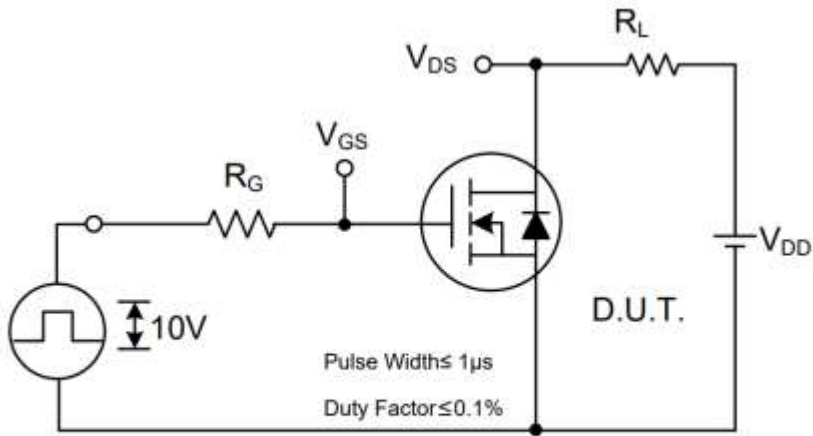

Switching Test Circuit

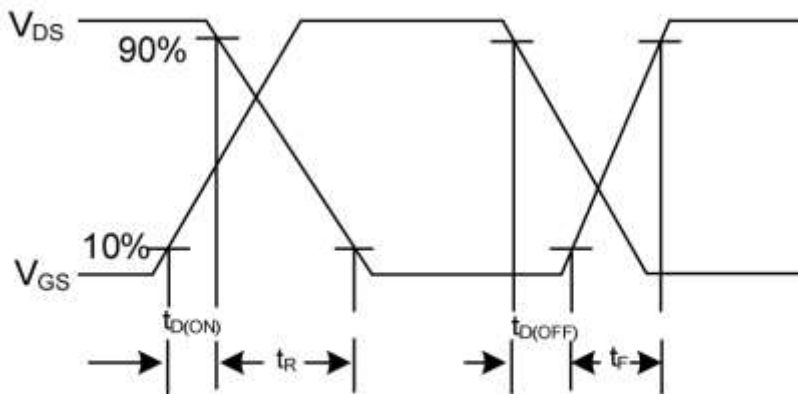

Switching Waveforms

SMD PLASTIC-ENCAPSULATE MOSFETS TO-252 SERIES

TEST CIRCUIT AND WAVEFORMS CURVE (For Reference Only)

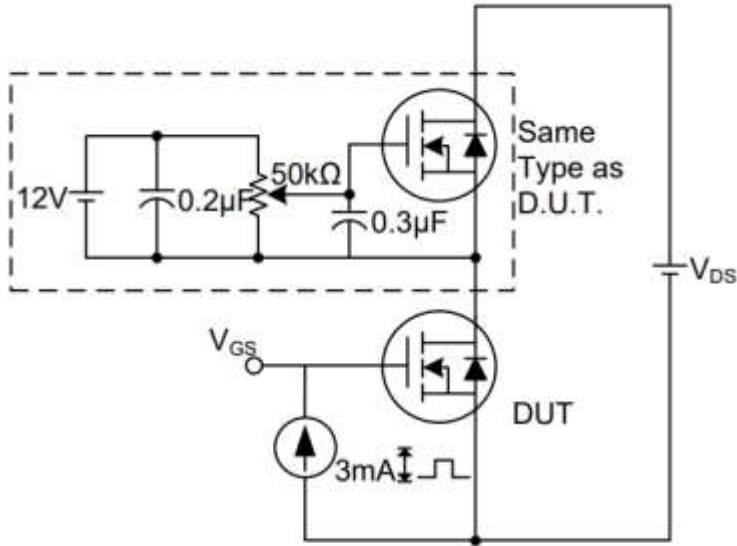

Gate Charge Test Circuit

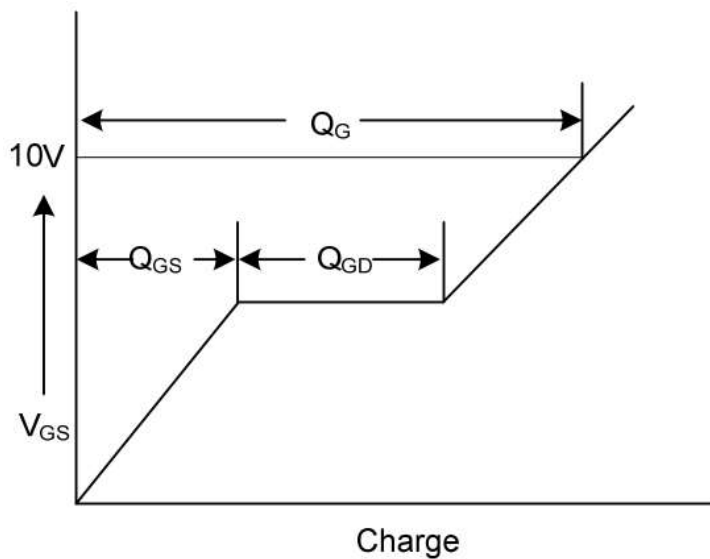

Gate Charge Waveform

SMD PLASTIC-ENCAPSULATE MOSFETS TO-252 SERIES

TEST CIRCUIT AND WAVEFORMS CURVE (For Reference Only)

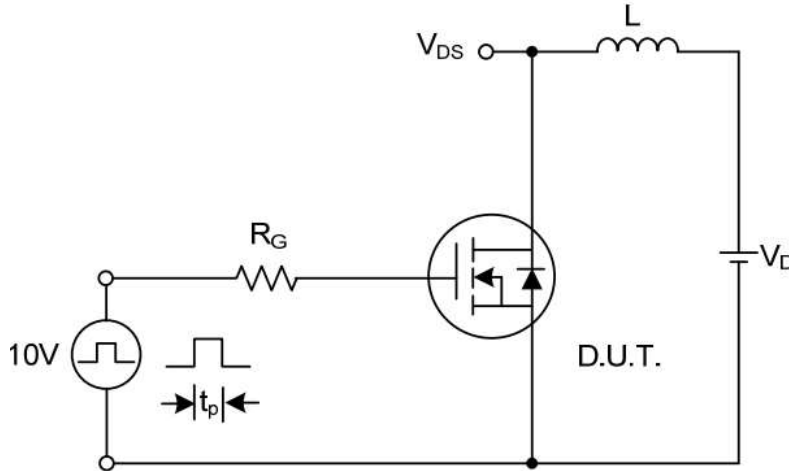

Unclamped Inductive Switching Test Circuit

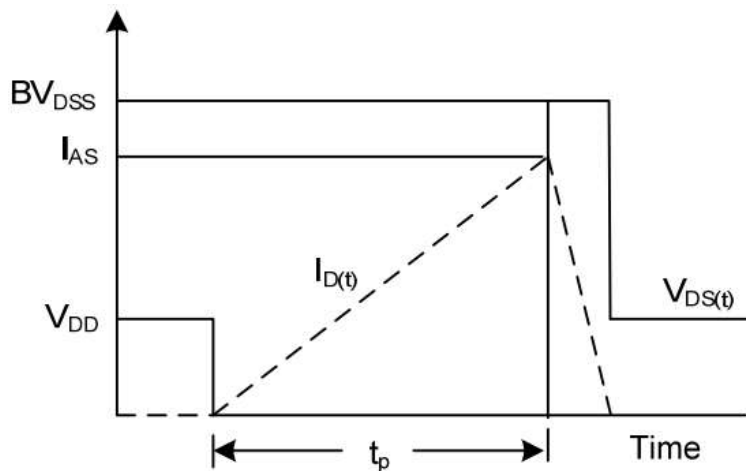

Unclamped Inductive Switching Waveforms

SMD PLASTIC-ENCAPSULATE MOSFETS TO-252 SERIES

TAPE/REEL For Reference Only (Unit: mm)

All Devices are packed in accordance with EIA standard RS-481-A and specifications.

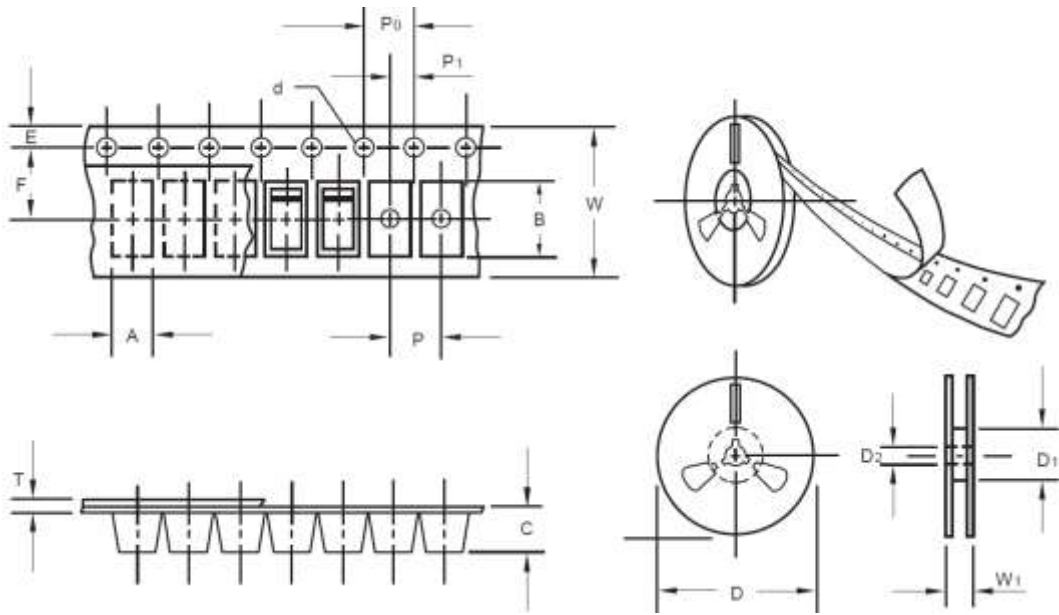

Item	Symbol	Tolerance	TO-252
Carrier width	A	0.1	6.15
Carrier Length	B	0.1	8.41
Carrier Depth	C	0.1	2.42
Sprocket hole	d	0.05	1.50
13"Reel outside diameter	D	2.0	330.00
13"Reel inner diameter	D1	Min.	50.00
7"Reel outside diameter	-	-	-
7"Reel inner diameter	-	-	-
Feed hole diameter	D2	0.5	13.00
Sprocket hole position	E	0.1	1.75
Punch hole position	F	0.1	7.50
Punch hole pitch	P	0.1	8.00
Sprocket hole pitch	P0	0.1	4.00
Embossment center	P1	0.1	2.00
Overall tape thickness	T	0.1	0.25
Tape width	W	0.3	16.00
Reel width	W1	1.0	16.50

SMD PLASTIC-ENCAPSULATE MOSFETS TO-252 SERIES

PACKAGE For Reference only

Case Code	TO- 252
Reel Size	13"
Reel Size	330 mm
SPQ/Reel	2500 pcs
Qty. /Box	5000 pcs
G.W/Box	3 lbs

DISCLAIMER

NextGen Component, Inc. reserves the right to make changes to the product(s) and or information contained herein without notice. No liability is assumed as a result of their use or application. No rights under any patent accompany the sale of any such product(s) or information

7/21/2023

20